

# Clanube®

## STRONG-ARM



## HYDRAULIC MOTORCYCLE LIFT

MODEL NO: CML7

PART NO: 7610201

## OPERATION & MAINTENANCE INSTRUCTIONS



ORIGINAL INSTRUCTIONS

DL 1023

---

## INTRODUCTION

---

Thank you for purchasing this CLARKE hydraulic motorcycle lift.

Before attempting to operate this product, it is essential that you read this manual thoroughly and carefully follow all instructions given. In doing so you can look forward to the product giving you long and satisfactory service.

---

## SPECIFICATIONS



---

Model Number	CML7
Maximum Load	360 kg (800lb)
Minimum Table Height	180 mm
Maximum Table Height	680 mm (excl wheel clamp)
Net weight inc Wheel Clamp	97.1kg
Wheel Clamp Max. Opening Width	180 mm
Table Length	1900 mm
Table Length with Ramp	2545 mm
Table Width	530 mm
Operating temperature range	0°C - 40°C

---

## SAFETY SYMBOLS

---

	Always read the user manual before use		Wear foot protection
	Warning: Risk of crushing of hands		

## SAFETY PRECAUTIONS

1. **NEVER** exceed the safe working load of 360kg (800lb) and only use the motorcycle lift for its intended purpose.
2. **NEVER** use the lift if it has been subjected to an abnormal load or shock. It should be removed from service immediately and fully inspected by qualified personnel before being passed as serviceable before being used again.
3. **NEVER** rely on the hydraulic ram to support the table when loaded. Always use the locking bar to hold the table in one of the two positions provided.
4. **NEVER** crawl or reach under the platform unless it is mechanically locked using the safety bar provided.
5. **ALWAYS** use the lift on a solid, flat, level surface.
6. **ALWAYS** screw down the 2 stabilisers at the front end of the lift before putting the table under load.

**NOTE:** *The castors are not designed to take the weight of the motorcycle but are used merely to move the lift quickly and easily around the workshop. On no account must you raise a loaded platform unless the stabilisers are screwed down, and NEVER use the lift to transport a load.*

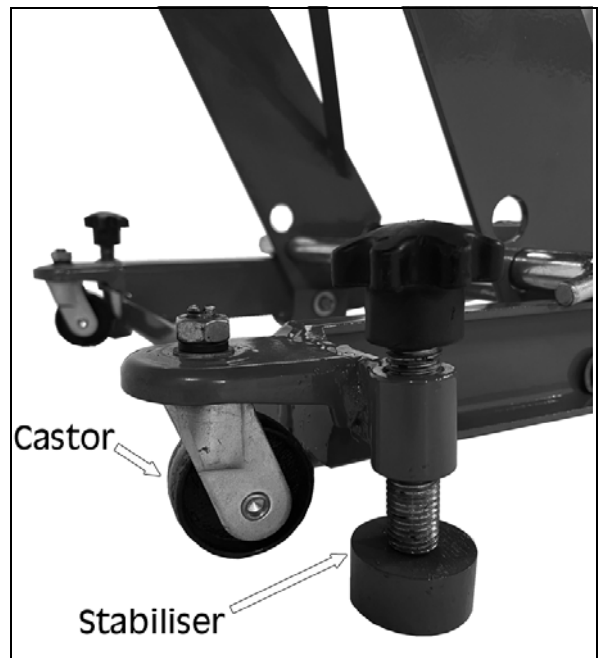

7. **ALWAYS** use appropriate safety equipment such as protective footwear when using this lift.
8. **ALWAYS** inspect the lift before use to ensure it is in good condition and replace any damaged or worn parts.
9. **ALWAYS** use spare parts supplied by CLARKE International. Using non-standard parts could be extremely dangerous.
10. **ENSURE** the operator is trained in both operational and safety aspects of using this product.
11. **NEVER** leave this lift unattended whilst there is a load on it.
12. **NEVER** allow children or bystanders anywhere near this lift whilst it is in use.

---

## ASSEMBLY & PREPARATION

---

Check to ensure that no damage has occurred during transit. Any damage should be reported to your CLARKE dealer immediately.

Using a clean, level area, unpack the equipment, laying out the loose items as follows:

- Main Lift
- Stop Plate
- Wheel Clamp
- Lifting Foot Pedal
- Ramp
- Safety Bar
- Removable Plate
- 4 x U Bolts
- Bolts, Washers, Nuts, Cotter Pins

The motorcycle lift is packed flat in its lowest position. It is fully assembled except for ancillary items which are fitted as follows.

1. Attach the stop plate to the front side of the platform using the nuts, bolts and washers provided, as shown.

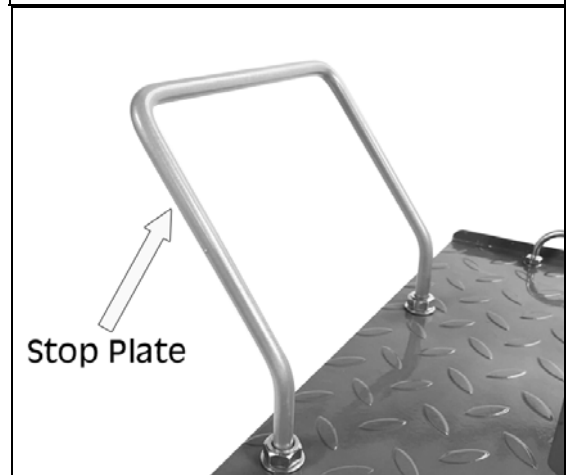

2. Attach the front wheel clamp to the front end of the platform using the nuts, bolts and washers provided, as shown. There are 3 different bolt hole positions to choose from.

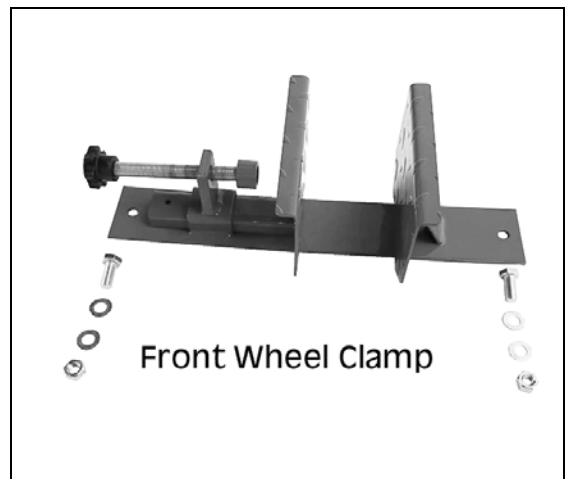

3. Slide the clamp plate into the clamp handle side of the clamp.

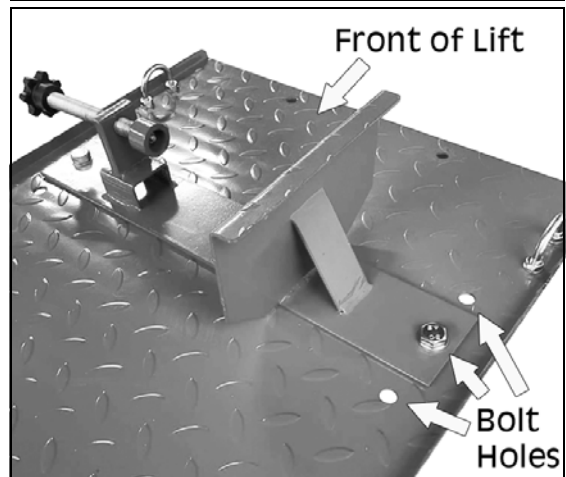

4. Attach the ramp to the rear side of the platform as shown.

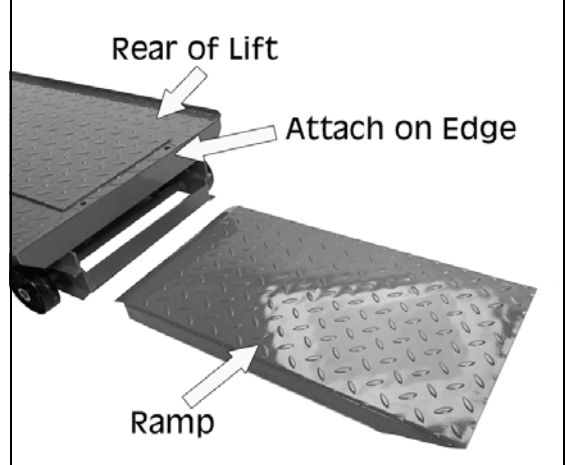
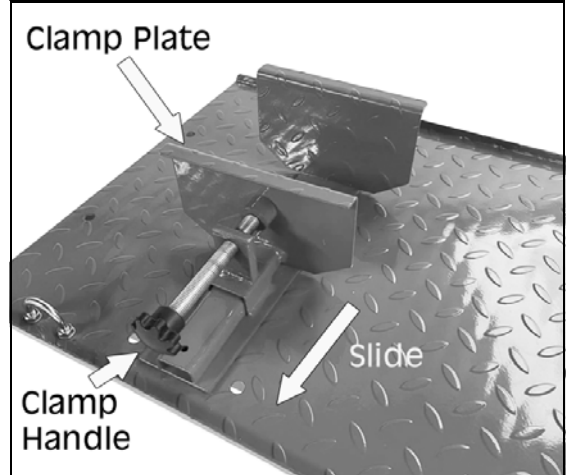

5. Attach the removable access plate over the rear access hole at the rear end of the ramp as shown.

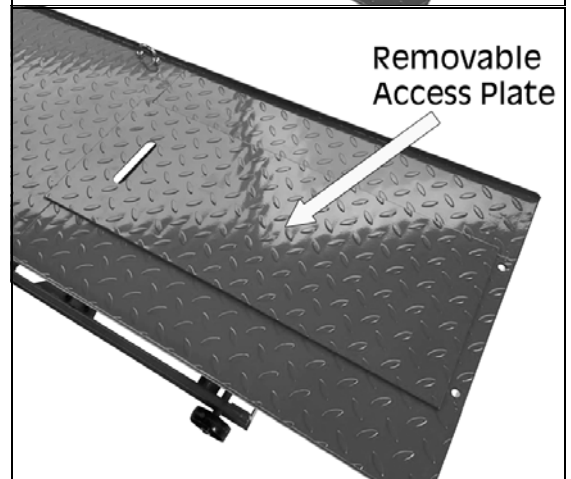
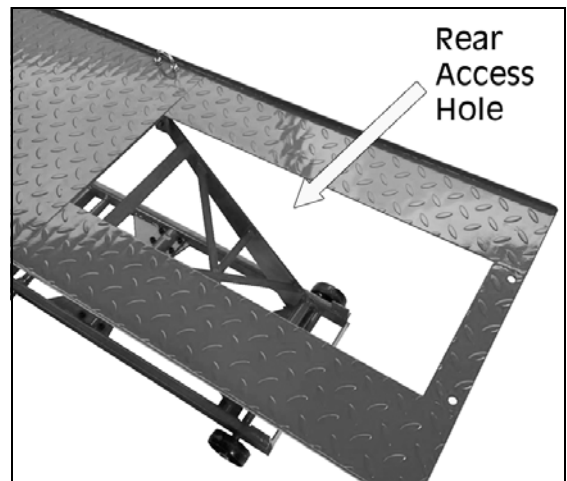

6. Attach the lifting foot pedal to the lifting spindle as shown.

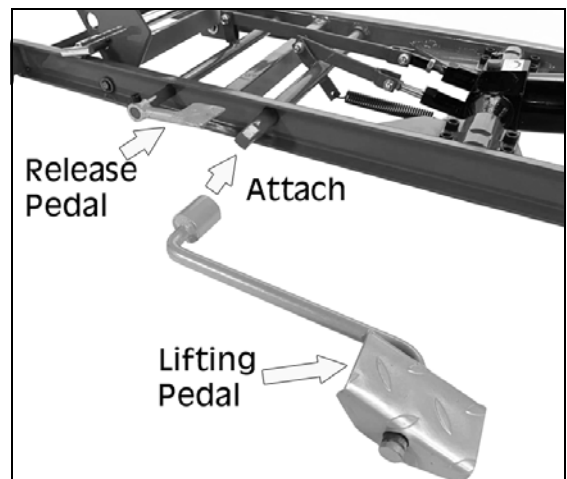

7. Attach the 4 U Bolts on to either side of the platform as shown.

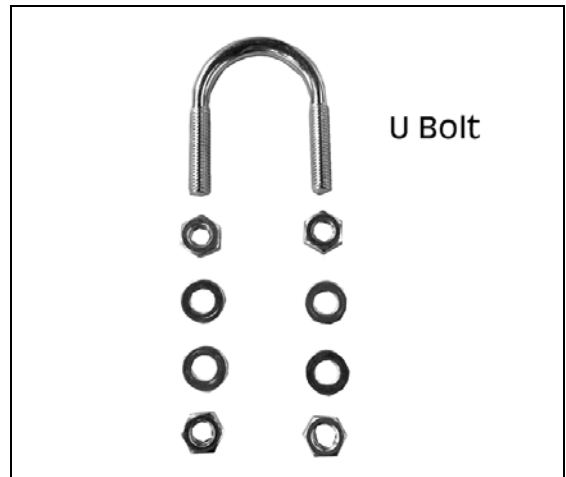

---

## BEFORE USE

---

Once unboxed and assembled, leave the lift for one hour to allow the oil to settle before purging the system.

**NOTE:** Failure to allow sufficient time for the oil to settle could result in air remaining in the oil. In this event, the pump will not purge completely the first time and a second purge will be required.

### PURGE AIR FROM THE HYDRAULIC SYSTEM

1. Lower the platform to its lowest position by depressing the release foot pedal.
2. Pump the lifting foot pedal several times to purge the air from the system.
3. Depress the release foot pedal.

- Carefully and slowly pinch the oil filler plug, that is situated on the top of the piston as shown, to release any trapped air.

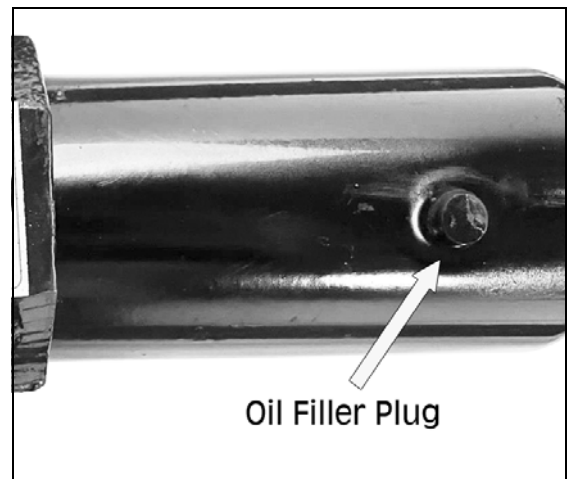

## DESCENT SPEED CONTROL SETTING

**NOTE: DO NOT** adjust the descent speed control while a motorcycle is on the platform

- Turn the black speed control valve on the piston pump to adjust the lowering speed of the lift.
  - Turn it counterclockwise to increase the descending speed.
  - Turn it clockwise to reduce the descending speed

**NOTE: DO NOT** adjust the red valve

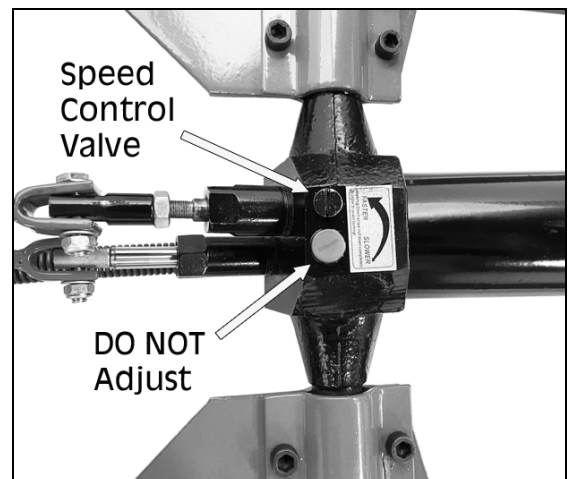



## OPERATION

Always carry out a visual check before use to ensure the lift is serviceable. Never take things for granted.

For safety purposes, loading the lift is essentially a two man operation.

**DO NOT exceed the maximum lifting capacity of 360kg (800lbs)**

**UNDER NO CIRCUMSTANCES** should you ride a motorcycle onto the lift, and on no account allow anyone to mount the motorcycle whilst it is on the table.

1. With the lift maneuvered to a suitable position which allows adequate working space, screw down the stabilizers, as shown, in order to take the weight off the casters and to prevent any possible movement of the table whilst working.
2. With the wheel clamp wide open, lower the table to its lowest position and with one person either side of the motorcycle, position it on the table so that the front wheel rests up against the stop plate.
3. Wind in the moveable wheel clamp to secure the front wheel and tighten.
4. Secure the motorcycle with straps using the U bolts, two each side of the table.

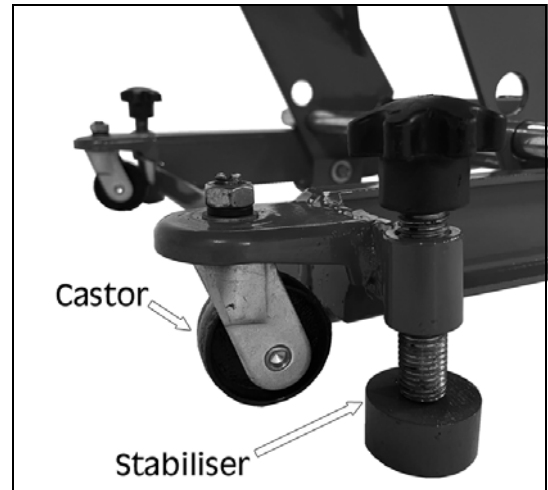

**WARNING: DO NOT USE THE MOTORCYCLE SIDE STAND ON THE LIFT, AS THIS WILL SHIFT THE CENTRE OF GRAVITY AND MAKE THE LIFT UNSTABLE.**

5. Before raising the table, check to ensure the motorcycle is perfectly stable.
6. Ensuring there is nothing to obstruct the table, press the lifting pedal repeatedly, and raise to an appropriate height to insert the safety bar.

**NOTE:** Two positions are provided into which the safety bar may be inserted, giving two working heights.

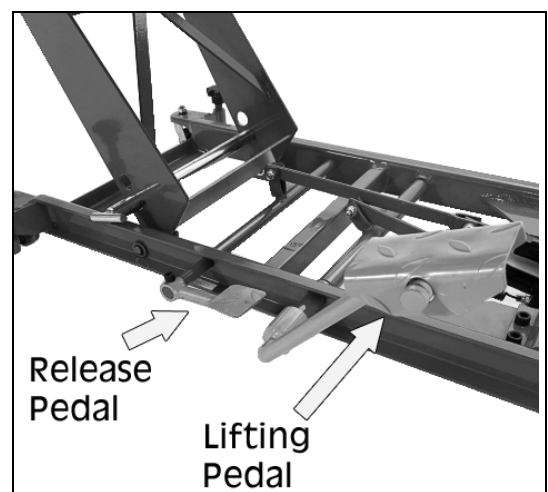

7. With the safety bar correctly inserted, lower the table using the lowering foot lever to ensure the full weight of the table is taken by the safety bar.
8. If the rear wheel is to be removed, ensure the motorcycle rests on its centre stand and is well lashed down. Alternatively, a Paddock Stand may be used to raise and secure the trailing axle. The cover of the opening, at the rear of the table, may be removed to facilitate the removal of the rear wheel.

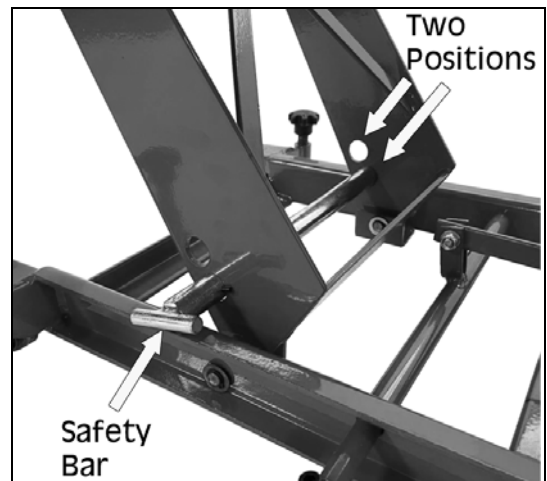

**WARNING: ENSURE THE FOLLOWING BEFORE COMMENCING WORK ON THE MOTORCYCLE:**

- The safety bar is inserted and the table lowered so that the safety bar is taking the FULL weight of the table
  - The motorcycle is securely strapped to the lift.
  - The stabilizers are screwed down to prevent the motorcycle lift from moving.
9. When you have finished working on the motorcycle, check under the lift to ensure that there are no obstructions and that it is safe to lower the lift. Press the lifting pedal once so the safety bar can be removed.
  10. Depress the release foot pedal and let the lift down slowly to its lowest position.
  11. Open the wheel clamp, untie the straps and remove the motorcycle via the ramp.

## **MAINTENANCE & TROUBLESHOOTING**

1. Keep the lift clean and wipe off any oil or grease. Lubricate all moving parts.
2. When not in use, the lift must be stored in its lowest position in a dry location to minimise ram and piston corrosion.
3. Before each use, check all parts to ensure that all bolts and nuts are firmly tightened. If any part of the lift is damaged or suspect, remove the lift from service and take necessary action to repair it.
4. Periodically check the ram and piston for signs of corrosion. Clean exposed areas with a clean oiled cloth.

5. When the lift efficiency drops, purge any air from the hydraulic system, see page 7-8.
6. Check the hydraulic oil level. If not adequate, add more hydraulic oil if necessary. **DO NOT** use brake fluid or any other improper fluid.
7. If the lift needs repairing and/or there are any parts that need to be replaced, have the lift repaired by a CLARKE authorised and trained technician and only use the replacement parts supplied by CLARKE International.

## TROUBLESHOOTING

PROBLEM	PROBABLE CAUSE	SOLUTION
Can't lift up the platform	1) The pump is leaking 2) Release valve not completely closed 3) Air in hydraulic system	1) Replace the oil seals, contact CLARKE dealer. 2) Check the release valve 3) Purge the air away, see page 7-8
Can't lower the platform	1) Speed control valve has been closed 2) Lack of lubrication	1) Turn the speed control valve counterclockwise, see page 8 2) Apply lubricating oil
The platform can't reach its highest position	1) Insufficient hydraulic oil	1) Add hydraulic oil, via the oil filler plug, see page 8
Oil leaking	1) Seals broken 2) Piston parts loose	1) Replace the seal kit, contact CLARKE dealer. 2) Tighten the piston parts

## GUARANTEE

This CLARKE product is guaranteed against faulty manufacture for a period of 12 months from the date of purchase. Please keep your receipt as proof of purchase.

This guarantee is invalid if the product is found to have been abused or tampered with in any way, or not used for the purpose for which it was intended.

Faulty goods should be returned to their place of purchase, no product can be returned to us without prior permission. This guarantee does not effect your statutory rights.

# PARTS LIST

ITEM	DESCRIPTION
1	Bolt M10x25
2	Bolt M12x30
3	Washer 12
4	Washer 10
5	Spring Washer 10
6	Nut M10
7	Support
8	Adjusting Screw
9	Washer 6
10	Nut M6
11	Castor Wheel
12	Washer 8
13	Bolt M8x20
14	Release Spindle
15	Release Foot Pedal
16	Lifting Spindle
17	Fixed Cover
18	Lifting Foot Pedal
19	Spring
20	Link
21	Pin
22	Circlip 12
23	Wheel
24	Washer 14
25	Circlip 14
26	Washer 10
27	Spring Washer 10

ITEM	DESCRIPTION
28	Bottom Frame
29	Nut M10
30	Bolt M8x35
31	Oil Release Link
32	Nut M8
33	Rear Arm Support
34	Pin
35	Washer 20
36	Ring 20
37	Bolt M10x10
38	Connector
39	Pump
40	Ramp
41	Movable Plate
42	Platform
43	Clamp Plate
44	Stop Plate
45	Clamp Handle
46	Clamp Bottom
47	Front Arm Support
48	Pin
49	Safety Bar
50	Nut M12
51	Washer 8
52	Speed Control Valve
53	Oil Filler Plug

# PART DIAGRAM

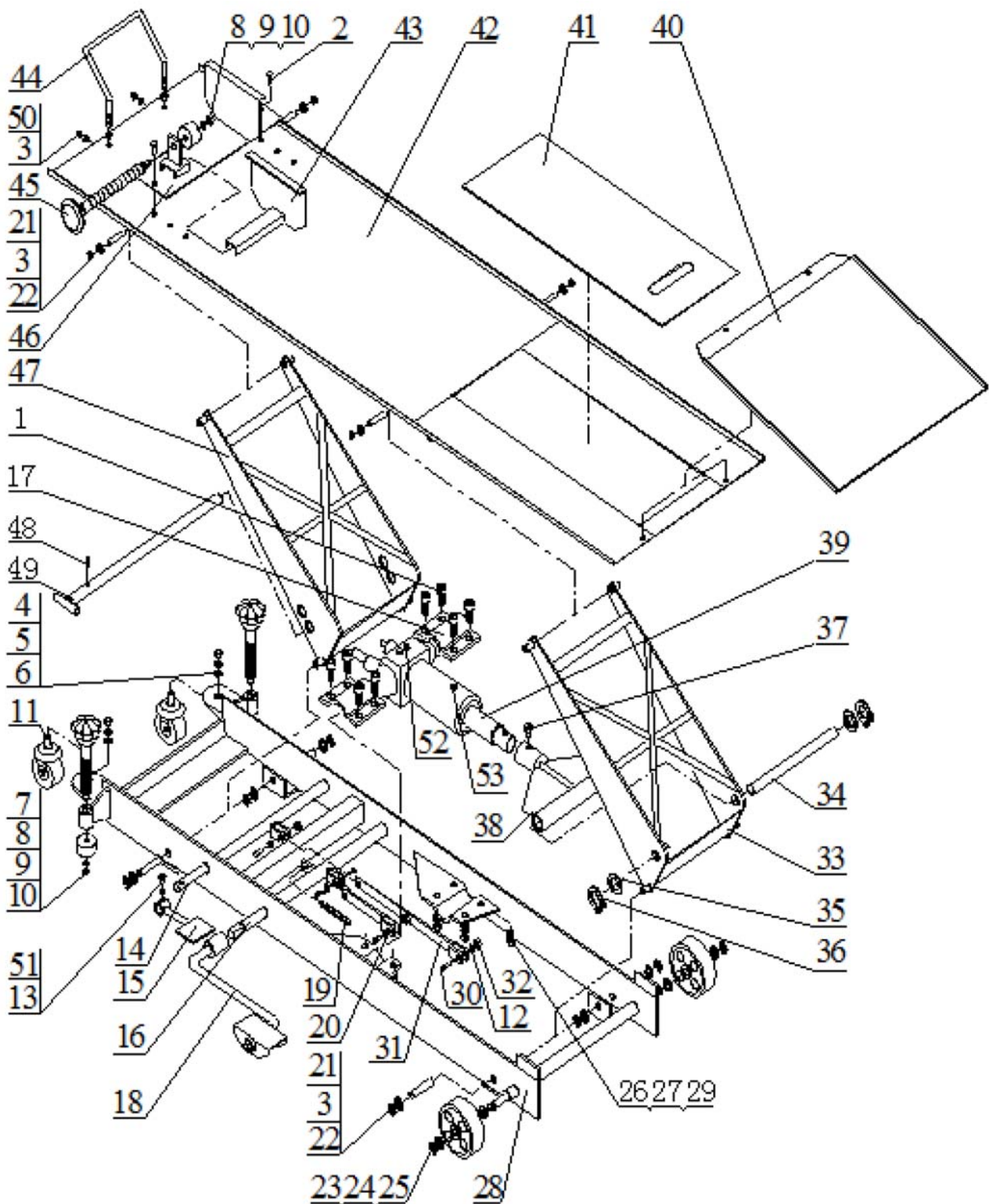

# DECLARATION OF CONFORMITY - UKCA



Hemnall Street, Epping, Essex, CM16 4LG

## DECLARATION OF CONFORMITY

This is an important document and should be retained.

We hereby declare that this product(s) complies with the following legislation:

*The Supply of Machinery (Safety) Regulations 2008*

The following standards have been applied to the product(s):

*BS EN 1493:2010, BS EN ISO 12100:2010*

The technical documentation required to demonstrate that the product(s) meet(s) the requirement(s) of the aforementioned legislation has been compiled and is available for inspection by the relevant enforcement authorities.

The UKCA mark was first applied in: 2023

Product Description:	Motorcycle Lift
Model Number(s):	CML7
Serial/Batch Number:	Refer to product/packaging label
Date of Issue:	15/09/2023

Signed:

J.A Clarke

Director

# DECLARATION OF CONFORMITY - CE



**Clarke**<sup>®</sup>  
**INTERNATIONAL**

Fitzwilliam Hall, Fitzwilliam Place, Dublin 2

## DECLARATION OF CONFORMITY

**This is an important document and should be retained.**

**We hereby declare that this product(s) complies with the following legislation:**

2006/42/EC                      *Machinery Directive*

**The following standards have been applied to the product(s):**

*BS EN 1493:2010, BS EN ISO12100:2010*

The technical documentation required to demonstrate that the product(s) meet(s) the requirement(s) of the aforementioned legislation has been compiled and is available for inspection by the relevant enforcement authorities.

**The CE mark was first applied in: 2023**

**Product Description:**                      Motorcycle Lift  
**Model Number(s):**                          CML7  
**Serial/Batch Number:**                      Refer to product/packaging label  
**Date of Issue:**                                15/09/2023

**Signed:**

**J.A Clarke**

**Director**

# A SELECTION FROM THE VAST RANGE OF

# Clarke®

## QUALITY PRODUCTS



**AIR COMPRESSORS**  
From DIY to industrial, Plus air tools, spray guns and accessories.

**GENERATORS**  
Prime duty or emergency standby for business, home and leisure.

**POWER WASHERS**  
Hot and cold, electric and engine driven - we have what you need

**WELDERS**  
Mig, Arc, Tig and Spot. From DIY to auto/industrial.

**METALWORKING**  
Drills, grinders and saws for DIY and professional use.

**WOODWORKING**  
Saws, sanders, lathes, mortisers and dust extraction.

**HYDRAULICS**  
Cranes, body repair kits, transmission jacks for all types of workshop use.

**WATER PUMPS**  
Submersible, electric and engine driven for DIY, agriculture and industry.

**POWERTOOLS**  
Angle grinders, cordless drill sets, saws and sanders.

**STARTERS/CHARGERS**  
All sizes for car and commercial use.



## PARTS & SERVICE: 0208 988 7400

**Parts Enquiries**  
[Parts@clarkeinternational.com](mailto:Parts@clarkeinternational.com)

**Servicing & Technical Enquiries**  
[Service@clarkeinternational.com](mailto:Service@clarkeinternational.com)

SALES: UK 01992 565333 or Export 00 44 (0)1992 565335

**Clarke** INTERNATIONAL Hemnall Street, Epping, Essex CM16 4LG  
[www.clarkeinternational.com](http://www.clarkeinternational.com)